

浙江金纬片板膜设备制造有限公司
ZHEJIANG JWELL SHEET&FILM EQUIPMENT CO.,LTD.

金纬机械 浙江厂区

地址：中国 浙江省 嘉兴市 海宁斜桥工业园 庆丰路128号

电话：0573-8778 6088 / +86 13917612260 (微信同号)

邮箱：salcc@jwell.cn / sales@jwell.cn

投诉邮箱：info@jwell.cn

网址：www.jwellhn.com / www.jwell.cn

JWELL MACHINERY ZHEJIANG FACTORY

Add:No.128, Qingfeng Road, Xieqiao Industrial Zone, Haining City, Zhejiang, China

Tel:+86-573-8778 6088 / +86 13917612260 (Whatsapp)

E-mail: salcc@jwell.cn / sales@jwell.cn

Complaint E-mail:info@jwell.cn

Website: www.jwellhn.com / www.jwell.cn

JWELL[®]
Professional Extrusion



www.jwell.cn

CAST FILM LINE

FOR
CPP/CPE/BARRIER FILM

流延膜生产线



NO.2023.10.CF

浙江金纬片板膜设备制造有限公司
ZHEJIANG JWELL SHEET & FILM EQUIPMENT CO.,LTD.

JWELL
Cast Extrusion Solution



www.jwell.cn

金纬机械 智能制造

浙江金纬片板膜设备制造有限公司是金纬机械旗下的又一个重要发展战略中心和制造基地，位于浙江省嘉兴市海宁斜桥工业园区。

公司专注于塑料薄膜挤出设备的设计、研发与制造。

公司产品已遍布全国各地，并出口到俄罗斯、印度、韩国、印尼、中东、非洲、南美洲、西班牙、意大利等100多个国家和地区，深受客户好评。

Zhejiang **JWELL** Sheet and Film Equipment Co., Ltd. is another important strategic development center and manufacturing base of **JWELL** Machinery. It is located in Xieqiao Industrial Park, Haining, Zhejiang Province. We focuses on the design, development and manufacturing of cast film extrusion equipment.

董事长：何海潮

Email: he@jwell.cn

President: He Haichao

Mobile: +86 13601628188



- 独特的T型模头，经过优化设计及流体仿真，确保出料均匀；
Special T-Die, better uniform flow with optimized design & simulation;
- 我们有几十年的螺杆结构设计经验，确保高产、高效；
We have decades of experience in extrusion screw design;
- 我们有高端的加工设备，确保核心零部件的加工精度；
We have high-end CNC to ensure the precision of the core parts;
- 我们有成熟的设计团队，确保生产线更加智能、更加高效、更加稳定。
We have a mature design team to make the cast film line smarter, more efficient and more stable.

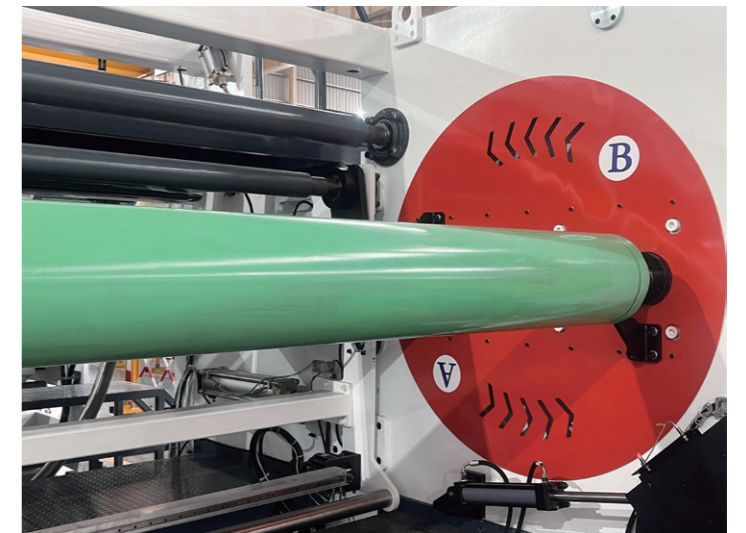

CPP流延膜机组 | CPP Cast Film Extrusion Line

制品用途 | Applications of product

- CPP薄膜经过印刷、制袋，可作为服装、针织品和花卉的包装袋；
After printing and bag making, CPP film can be used as packaging bags for clothing, knitwear and flowers;
- 可用于食品外包装，糖果外包装，药品包装等。
Can be used for food packaging, candy packaging, pharmaceutical packaging, etc.

生产线规格型号 | Production Line Specification

机型 Model	口模宽度 Width of die mm	制品宽度 Products width mm	制品厚度 Products thickness mm	机械运行速度 Max line speed m/min	最大产量 Max capacity kg/h
JCF-3000PP	3000	2700	0.02-0.12	250	800
JCF-3500PP	3500	3200	0.02-0.12	250	1000
JCF-4500PP	4500	4200	0.02-0.12	250	1400
JCF-5500PP	5500	5200	0.02-0.12	250	1600

- 全自动调节模头，可实现在线闭环控制；
Fully automatic adjustment of the die head, enabling online closed-loop control;
- 薄壁高效冷却成型辊，特殊螺旋流道设计，保证高速生产时薄膜定型效果的一致；
Thin-walled high-efficiency cooling forming roller and special spiral flow channel design ensure consistent film shaping effect during high-speed production;
- 配套负压双腔真空箱和静电压边装置，保证薄膜熔膜稳定；
Equipped with negative pressure double chamber vacuum box and static edge locking device to ensure the stability of film fusion;
- 高稳定性电晕处理装置，故障率低，可根据需要转换走向，处理薄膜的正反面。
High-stability corona treatment device with low failure rate. It can switch directions as needed to process the front and back sides of the film.

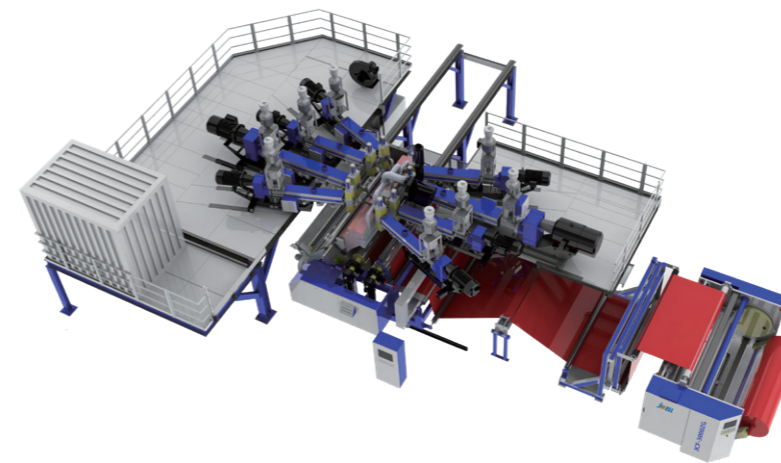
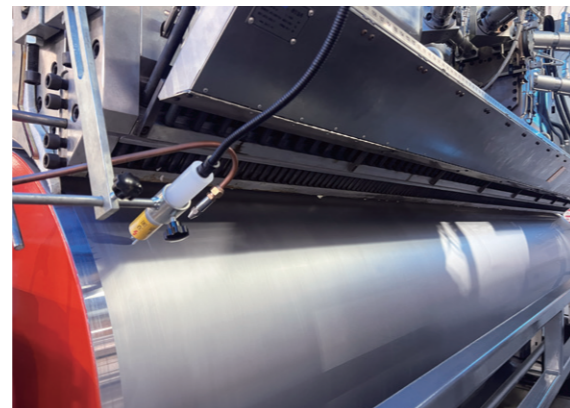
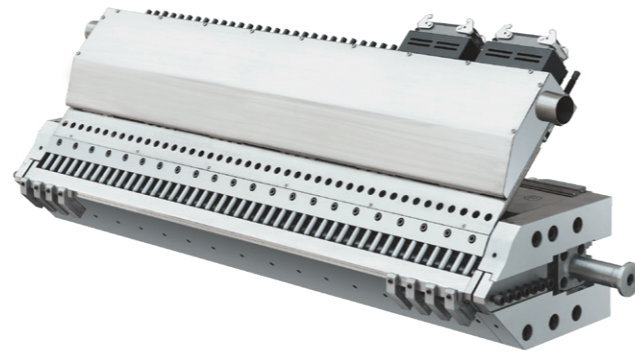

金纬机械具备生产最高9层高阻隔流延膜生产线的的能力；
该设备适应性强，可针对不同牌号的PE、PP、PA、EVOH原料进行优化适应。

JWELL Machinery has the ability to produce up to 9 layers of high barrier cast film production lines; The equipment has strong adaptability and can be optimized and adapted to different brands of PE, PP, PA and EVOH raw materials.

CPE流延膜机组 | CPE Cast Film Extrusion Line

制品用途 | Applications of product

- CPE复合基材膜：可与BOPA、BOPET、BOPP等产品复合-热封-制袋，应用于食品、服装等领域；
CPE composite base film: It can be laminated, heat sealed and bag-made with BOPA, BOPET, BOPP and other products, and is used in food, clothing and other fields;
- CPE单层印刷膜：经热印-热封-制袋，应用于卷纸提袋包装、纸巾独立包装等；
CPE single-layer printing film: after heat printing-heat sealing-bag making, it can be used for roll paper bag packaging, paper towel independent packaging, etc.;
- CPE镀铝膜：广泛用于软包装、复合包装，装潢、激光全息防伪、激光压印镭射等。
CPE aluminum coated film: widely used in flexible packaging, laminated packaging, decoration, laser holographic anti-counterfeiting, laser embossing laser, etc.

生产线规格型号 | Production Line Specification

机型 Model	口模宽度 Width of die mm	制品宽度 Products width mm	制品厚度 Products thickness mm	机械运行速度 Max line speed m/min	最大产量 Max capacity kg/h
JCF-2500PE	2500	2200	0.02-0.15	250	600
JCF-3000PE	3000	2700	0.02-0.15	200	750
JCF-3500PE	3500	3200	0.02-0.15	200	900

金纬机械 JWELL-JCF 控制系统

- 检测、控制和调节
Detection, control and regulation
- 挤出机和模头的温度、压力监测
Temperature and pressure detection of extruder and die head
- 牵引、收卷速度控制及监测
Control and monitor the traction and winding speed
- 同步提速、降速及整线联动
Synchronous acceleration, deceleration and linkage of the whole line
- 产量控制及显示
Extrusion output control and display
- 故障提示及警告
Fault prompts and warnings

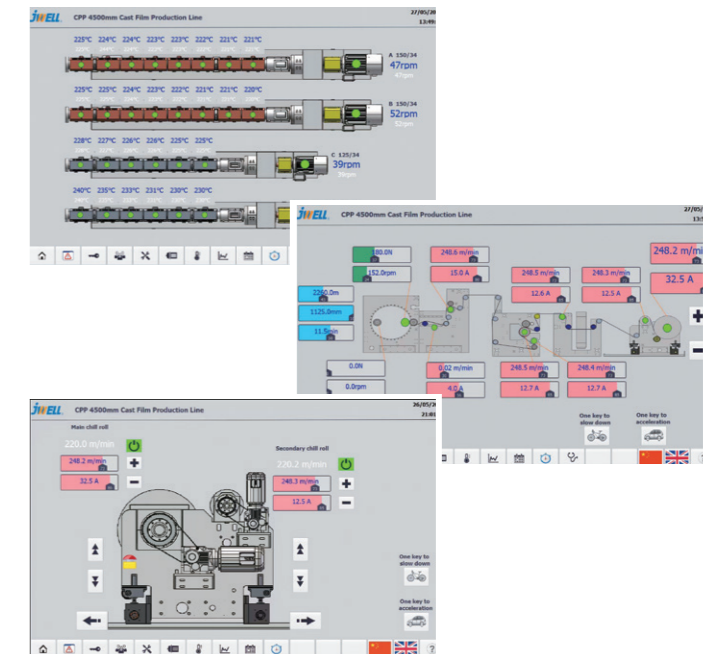

高阻隔流延膜机组 | High Barrier Cast Film Extrusion Line

生产线规格型号 | Production Line Specification

机型 Model	口模宽度 Width of die mm	制品宽度 Products width mm	制品厚度 Products thickness mm	机械运行速度 Max line speed m/min	最大产量 Max capacity kg/h
JCF-2500ZG	2500	2200	0.03-0.25	150	600
JCF-3000ZG	3000	2700	0.03-0.25	150	700

金纬机械 **JWMD** 系列医疗级流延膜生产线，按万级实验室要求打造，具有占地面积小、多用途、设备轻量化设计、拆装方便等特点。

The **JWMD** series medical grade cast film production line of JWELL Machinery is built according to the requirements of a 10,000-level laboratory. It has the characteristics of small floor space, multi-purpose, light-weight equipment design, and easy disassembly and assembly.

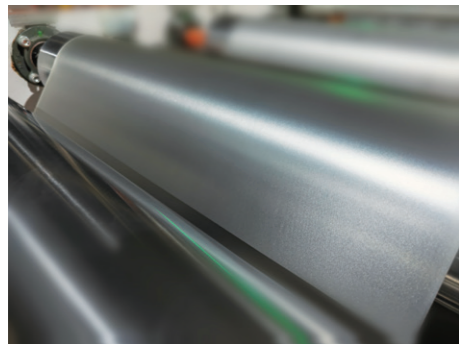
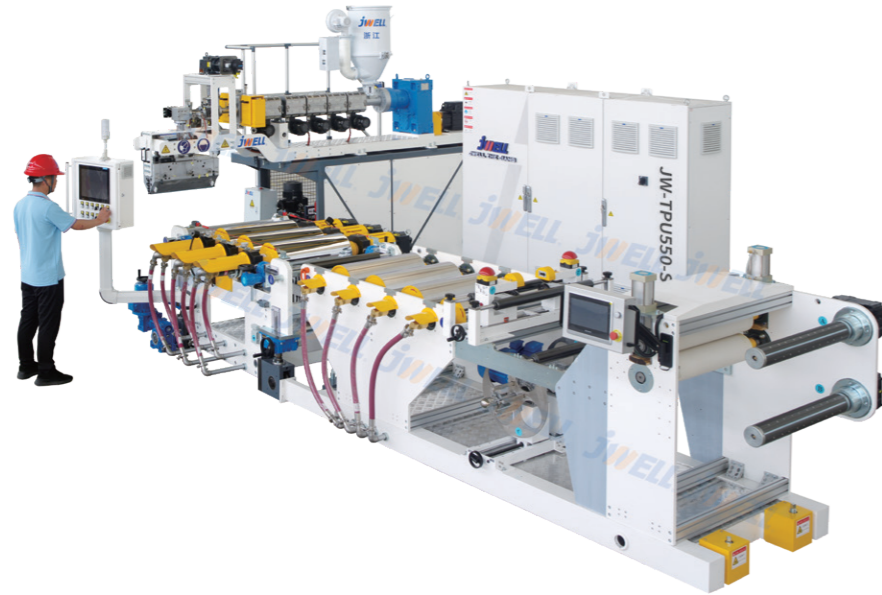

JWMD 系列生产线应用领域

- TPU/EVA医用膜，用于输液袋、血浆袋、伤口敷料等
TPU/EVA medical film, used for infusion bags, plasma bags, wound dressings, etc.
- TPU/PETG 牙片，用于牙齿整形
TPU/PETG dental tablets for tooth shaping
- PE隔离膜，防护服
PE isolation film, protective clothing

医疗级流延膜生产线 | Medical Grade Cast Film Extrusion Line

生产线规格型号 | Production Line Specification

机型 Model	口模宽度 Width of die mm	制品宽度 Products width mm	制品厚度 Products thickness mm	机械运行速度 Max line speed m/min	最大产量 Max capacity kg/h
JCF-400MD	400	200	0.1-0.5	10	10
JCF-600MD	600	400	0.1-0.5	10	15
JCF-800MD	800	600	0.1-0.5	10	20

EVA/POE 胶膜：用于太阳能光伏电站、建筑物玻璃幕墙、汽车玻璃、功能性棚膜、包装膜、热熔胶等各种行业。

EVA/POE film is used in solar photovoltaic power station, building glass curtain wall, automobile glass, functional shed film, packaging film, hot melt adhesive and other industries.



PVB/SGP 胶膜：广泛应用于建筑夹层玻璃，汽车夹层玻璃，防弹玻璃，隔音玻璃等。具有很好的安全性，防止玻璃由于外力作用下破碎而碎片溅起伤人；具有隔音性，防紫外线，可以做成彩色或高透明的薄膜。

PVB/SGP film: widely used in building laminated glass, automotive laminated glass, bulletproof glass, sound-proof glass, etc. It has good safety and prevents the glass from breaking due to external force and the fragments splashing and hurting people; it has sound insulation and UV protection, and can be made into colored or highly transparent films.

EVA/POE/PVB/SGP胶膜生产线 | EVA/POE/PVB/SGP Film Extrusion Line

生产线规格型号 | Production Line Specification

机型 Model	适用原料 Suitable material	制品宽度 Products width mm	制品厚度 Products thickness mm	设计线速度 Designed line speed m/min	设计挤出产量 Capacity kg/h
JWS120/150/120-2400	EVA/POE	2000-2400	0.38-1.0	15	700-750
JWS180-2400	EVA/POE	2000-2400	0.38-1.0	12	600-700
JWS150	PVB/SGP	2000-2600	0.38-1.52	10	400-500
JWE95-JWE65	PVB/SGP	2400-3000	0.38-1.52	10	600-700
JWE135-JWE95	PVB/SGP	3000-3600	0.38-1.52	20	1000-1200

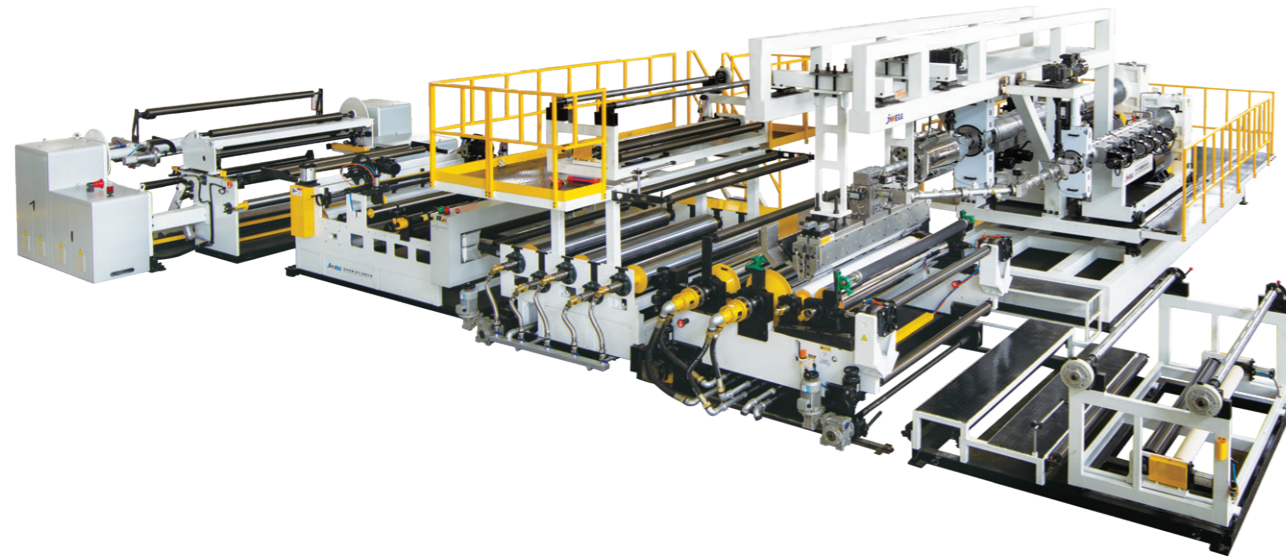

TPU高低温薄膜/高弹膜生产线 TPU High-low Temperature / High-elastic Film Co-extrusion Line

生产线特点: 通过2台或3台挤出机共挤的方式, 将不同温度范围和硬度范围的TPU原料, 一次性复合挤出成型。相比传统复合工艺, 将高温、低温薄膜下线再复合, 显得更经济、更环保、更高效。制品广泛应用于止水条、鞋材、服装、箱包、文具、体育用品等等。

Features: Through co-extrusion of 2 or 3 extruders, TPU raw materials with different temperature ranges and hardness ranges can be extruded at one time. Compared with traditional processes, laminating high-temperature and low-temperature films offline is more economical, environmentally friendly, and efficient. Products are widely used in waterproof strips, shoe materials, clothing, bags, stationery, sporting goods, etc.

生产线规格型号 | Production Line Specification

机型 Model	制品宽度 Products width mm	制品厚度 Products thickness mm	设计挤出产量 Capacity kg/h
JWS90+JWS100	1000-2000	0.02-0.5	200-250
JWS90+JWS90+JWS90	1000-2000	0.02-0.5	200-300

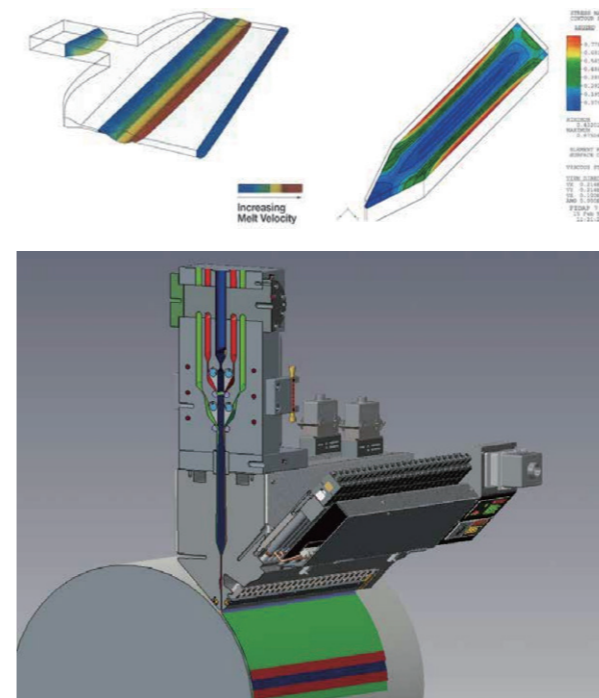

对于特殊的薄膜应用领域, **JWELL** 为薄膜生产线配置了在线的 **MDO** 单元。单轴拉伸工艺使得薄膜成型在如下方面变的可控, 如拉伸强度、收缩率、刚度、阻隔性和光学特性等。此外, 通过拉伸来达到薄膜的轻量化, 仍将引领着流延膜行业增长的趋势。

For special film applications, **JWELL** has equipped the film extrusion line with an online **MDO** unit. The uniaxial stretching process makes film forming controllable in terms of tensile strength, shrinkage, stiffness, barrier properties and optical properties. In addition, the lightweighting of films through stretching will continue to lead the growth trend of the cast film industry.

金纬机械在线MDO单元 | Jwell Machinery Online MDO Unit

我们具有多年的MDO相关经验积累
With many years of experience in MDO

产品应用 | Product application

- 自黏胶带
Self-adhesive tapes
- 手拆撕条
Hand tear strips
- 标签膜
Label film
- 泡沫膜-珍珠棉
Foamed film
- 用于PET抗老化、收缩率优化
Used for PET anti-aging and shrinkage optimization
- 阻隔膜
Barrier film

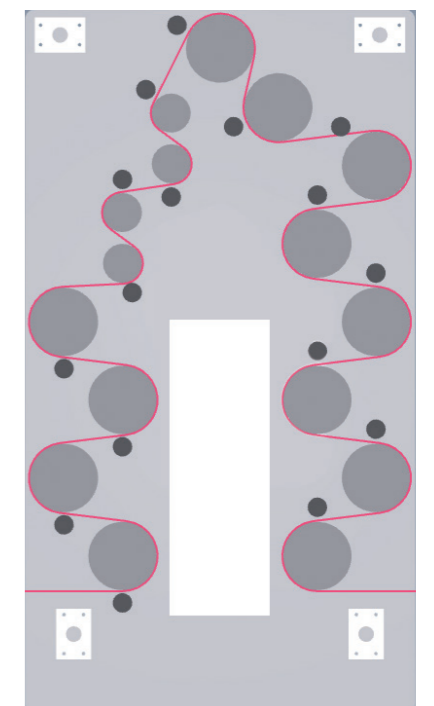

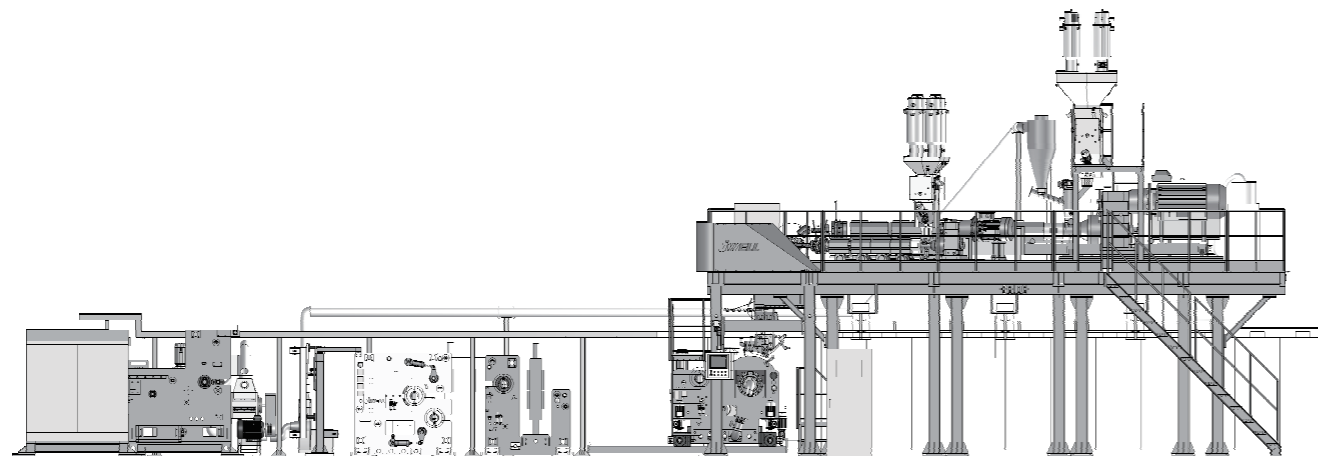

CPP流延装饰膜生产线 CPP Cast Decorative Film Extrusion Line

产品特点 | Features

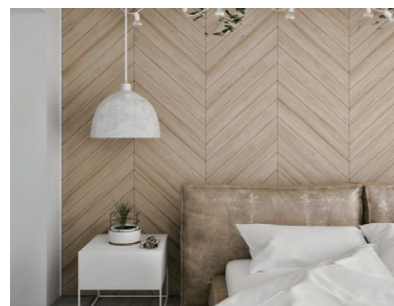

- 环保性 Environmental protection:**
 PVC在燃烧过程中产生有害气体，PP无毒无害。
 PVC produces harmful gas during combustion, and PP is non-toxic and harmless.
- 耐久性 Durability:**
 PP表面耐磨性，耐高温性，立体性，抗冲击性远高于PVC制品。
 PP surface has better wearproof, high temperature resistance and impact resistance than PVC products.
- 高仿真 High imitation:**
 仿木纹、大理石、皮革、拉丝等。
 This film can be made to be imitation wood grain, marble, leather, brushed satin, etc.
- 应用领域 Application fields:**
 建筑装饰和包装，国家认证环保产品。
 It is used in the field of building and ornament materials, packaging materials, and nationally certified environmental protection products.

生产线规格型号 | Production Line Specification

机型 Model	模头宽度 T-die mm	制品宽度 Products width mm	产量 Capacity kg/h	分层 Layers
JCFPP-1650ZS-2	1650	1350	350-450	ABA LAYER
JCFPP-2900ZS-4	2900	2600	700-800	ABCD LAYER

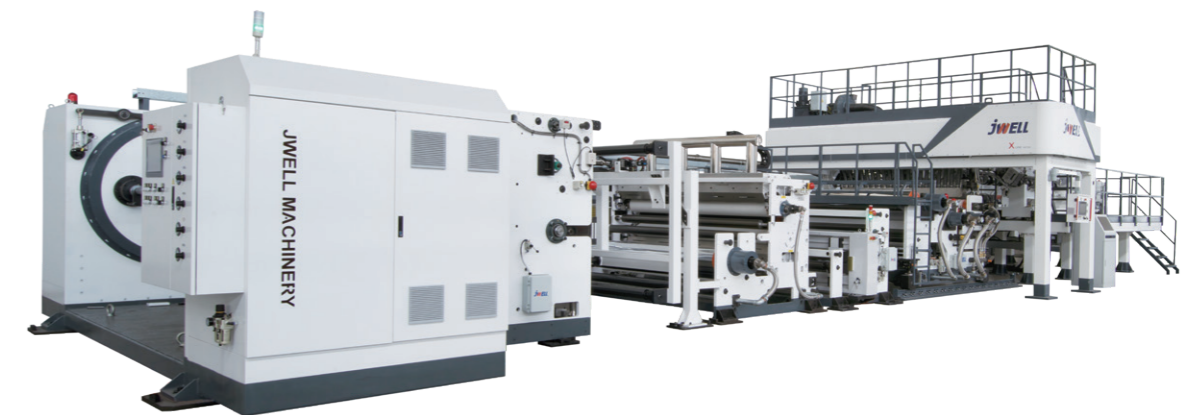

CPE压纹透气膜生产线 Cast Embossed Breathable Film Extrusion Line

产品特点 | Features

- 透气性 Breathability:**
 制品可在透气性和非透气之间转换。
 The film can be made to be breathable or non-breathable.
- 触感 Touch:**
 外观独特，具备优质肤感，接触时并无沙沙声。
 Unique appearance with premium skin feel and no rustling sound.
- 智能化 Intelligence:**
 配备自动厚度控制系统和高效的冷却辊，可生产透明度好、厚度变化小的CPE薄膜，配备了重量法批量计量系统，恒定气流切割。可控拉伸、可控定向。压纹、印刷、复合等都极为方便。
 Equipped with automatic thickness control system and efficient cooling roller, it can produce CPE film with good transparency and small thickness change, equipped with gravimetric batch metering system, constant air flow cutting. Controllable stretch, controllable orientation. Embossing, printing, compounding, etc. are all very convenient.



应用领域 | Application Fields

- 用于婴儿和成人的尿布的外层。Outer layer of diapers for babies and adults.
- 用于女性卫生用品的薄膜。Films for feminine hygiene products.
- 隔离衣，防护服。Isolation gowns, protective clothing.
- 保护膜：家具、汽车等表面保护的物品。Protective film: items for surface protection such as furniture and cars.

生产线规格型号 | Production Line Specification

机型 Model	螺杆直径 Screw diameter mm	模头宽度 T-die mm	制品净宽 Products width mm	制品厚度 Product thickness mm	线速度 Line speed m/min
JCFPE-120-1900	Φ120	1900	1600	0.02-0.15	180
JCFPE-125-2300	Φ125	2300	2000	0.02-0.15	180
JCFPE-135-2800	Φ135	2800	2500	0.02-0.15	180



PE自粘保护膜 PE Self-adhesive Protective Film Extrusion Line



应用领域: PE自粘保护膜是一种保护膜，被广泛应用于金属、装饰面板、玻璃等产品上，以及对胶水敏感的电子物品的表面保护上。

Application Field: PE self-adhesive protective film is widely used in electroplating, Metal surface, decorative panel, glass and other products, as well as surface protection of glue-sensitive electronic items.

优势: 它具有更环保，更洁净，更稳定，贴合方便，不易脱落等优点。自粘意为表面自带粘性，而非涂胶，从产品表面撕除后无残胶。PE自粘保护膜最大的优点是被保护的产品在生产加工、运输、贮存和使用过程中不受污染、腐蚀、划伤，保护原有的光洁白净的表面，从而提高产品的质量及市场竞争力。

Advantages: It has the advantages of being more environmentally friendly, cleaner, more stable, easy to fit, and not easy to fall off. Self-adhesive means that the surface is self-adhesive, not glued, and there is no residual glue after being torn off from the surface of the product. The biggest advantage of PE self-adhesive protective film is that the protected product will not be polluted, corroded, scratched during production, processing, transportation, storage and use, and protect the original smooth and shiny surface, thereby improving product quality and market competitiveness.

应用行业: PE自粘保护膜被广泛应用于五金行业、光电行业、塑胶行业、印刷行业、装饰建材行业等领域。

Application Industry: PE self-adhesive protective film is widely used in hardware industry, optoelectronic industry, plastic industry, printing industry, decorative building material industry and other fields.



FILMLAB系列流延试验线 FILMLAB Series Casting Film Texturing Line

应用场景: 高校实验室、科研单位、石油化工、原料改性、配方开发等。

Application scenario: University laboratories, scientific research units, petrochemical industry, raw material modification, formulation development, etc.

生产线特点 | Production Line Features

- 采用全伺服驱动，确保生产线运行精确、低噪音、低震动。
Full servo drive to ensure accurate operation, low noise, low vibration of the production line.
- 采用模块化设计，使得生产线具备多用途的能力。
The modular design makes the production line have the ability of multi-use.
- 更高的安全设计标准、更小的占地空间。
Higher safety design standards, smaller footprint.



- 多种放射性测量探头可供选择，如果需要，我们还可以将厚度检测系统与自动模头集成在一起；
A variety of radioactive measurement probes are available, and if required, we can also integrate the thickness detection system with the automatic die;
- 生产过程中所产生的边料可实现在线回收利用，通过多组分下料装置，将粉碎后的回收料输送至挤出机；
The edge material produced in the production process can be recycled online, and the edge material after crushing is transported to the extruder through the multi-component feeding device;
- 我们能提供全自动收卷、卸卷，可大大降低人工成本。
We can provide automatic winding and unwinding machine, which can greatly reduce the labor cost.

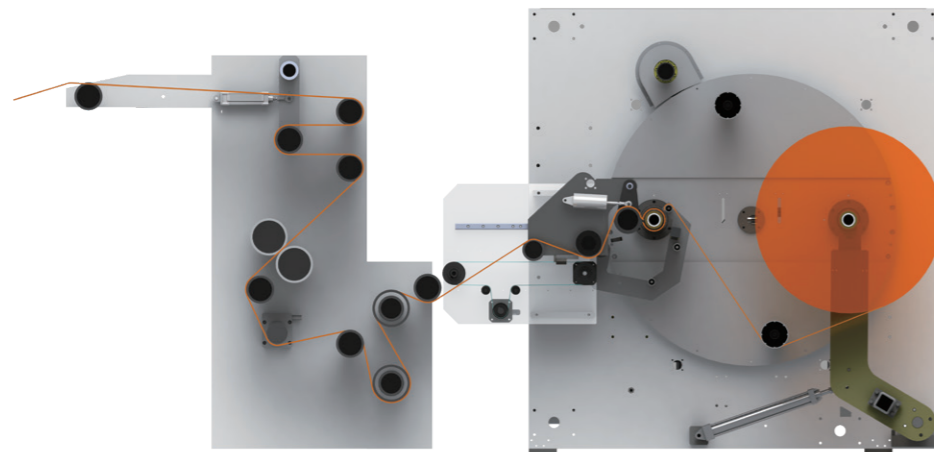
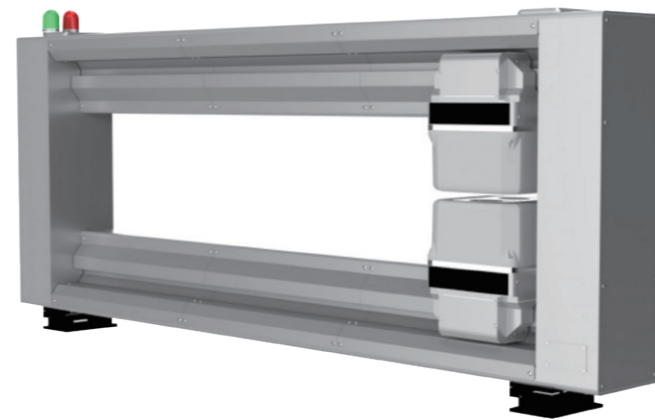

- 金纬公司的全自动收卷机，可实现高收卷质量，大多数情况下，您可以直接对卷材进行后续加工，而无需复卷；
JWELL automatic winding machine can achieve high winding quality. In most cases, you can directly process the coil without rewinding;
- 经过不断优化，金纬公司的收卷机已经可以将收卷直径提高至1200mm。
JWELL winding machine is optimized to match the diameter of the winder up to 1,200 mm.

优质的产品 Excellent product

